

Designer Wood ADA Locker Bench (without back) Assembly & Installation Instructions

Thank you for selecting Salsbury Designer Wood ADA locker benches. We are confident that the quality and construction of this product will provide years of maintenance free use.

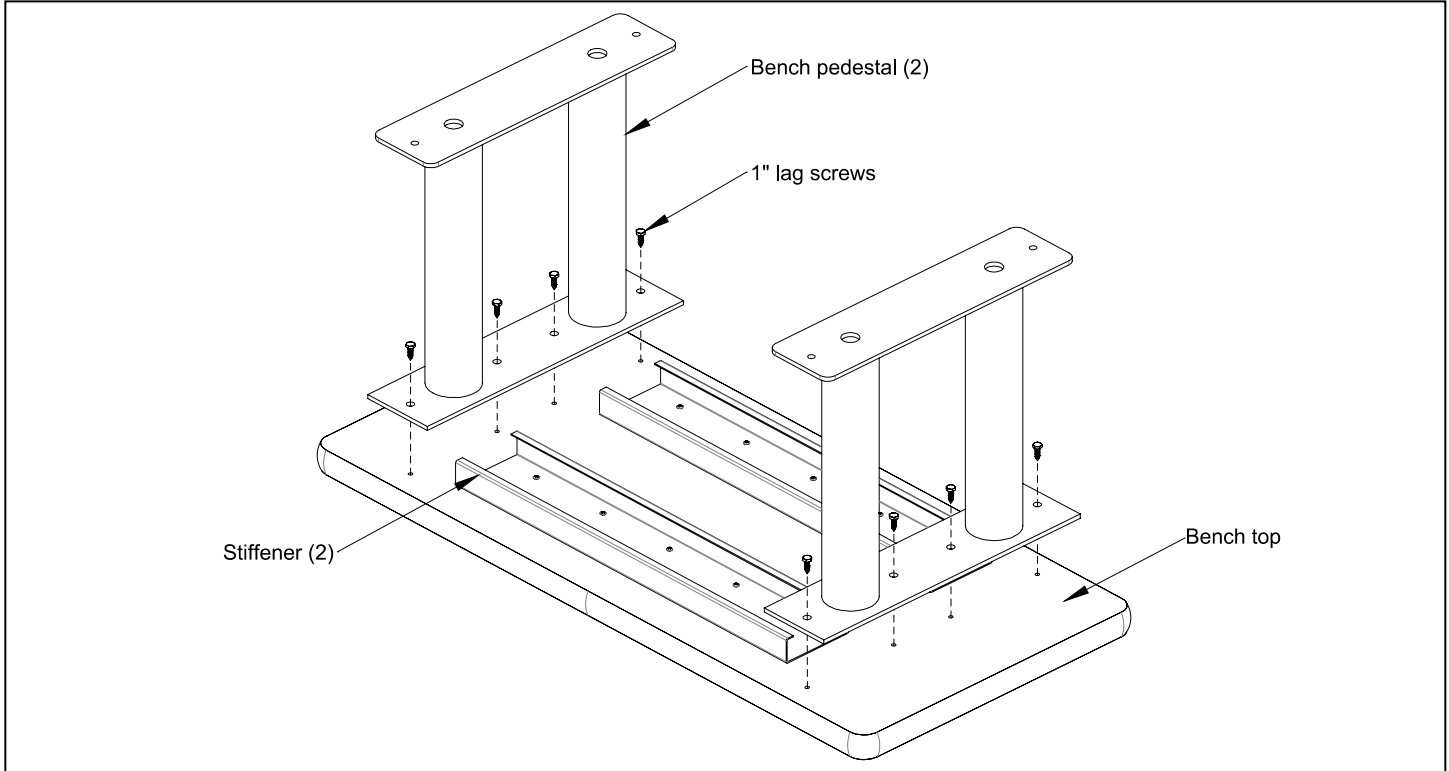

Preliminary Notes

There are two basic steps to assembly and installation:

1. The bench pedestals must be assembled to the bench top.
2. The bench assembly must be bolted to the floor.

Failure to bolt the bench assembly to the floor could result in injury to persons sitting on the bench.

Since various types of floors require different types of fasteners, floor installation hardware is not provided.

Two bench pedestals are provided for each bench top, along with two stiffeners pre-installed on the bench top. All necessary holes are pre-drilled in the wood bench top. Eight (8) 1/4" diameter x 1" long lag screws are provided for attaching the bench pedestals to the bench top.

CAUTION: using power tools to fasten screws into the bench top may cause screws to strip and damage the wood. Install screws by hand only and do not overtighten.

Assembly

Place the bench top upside down on a flat surface, so that the stiffeners are facing up. Align the two bench pedestals with the two outer rows of holes, placing the plates with non-rounded corners against the bench top as shown in Figure 2. Fasten pedestals to the bench top using the included lag screws.

Complete the installation by fastening the assembled bench to the floor.

SALSBURY INDUSTRIES

18300 Central Avenue, Carson, CA 90746-4008
Phone: 1-800-562-5377 Int'l Phone: 323-846-6700
Fax: 1-800-562-5399 Int'l Fax: 323-846-6800
www.lockers.com engineering@lockers.com

Designer Wood ADA Locker Bench (with back) Assembly & Installation Instructions

Thank you for selecting Salsbury Designer Wood ADA locker benches. We are confident that the quality and construction of this product will provide years of maintenance free use.

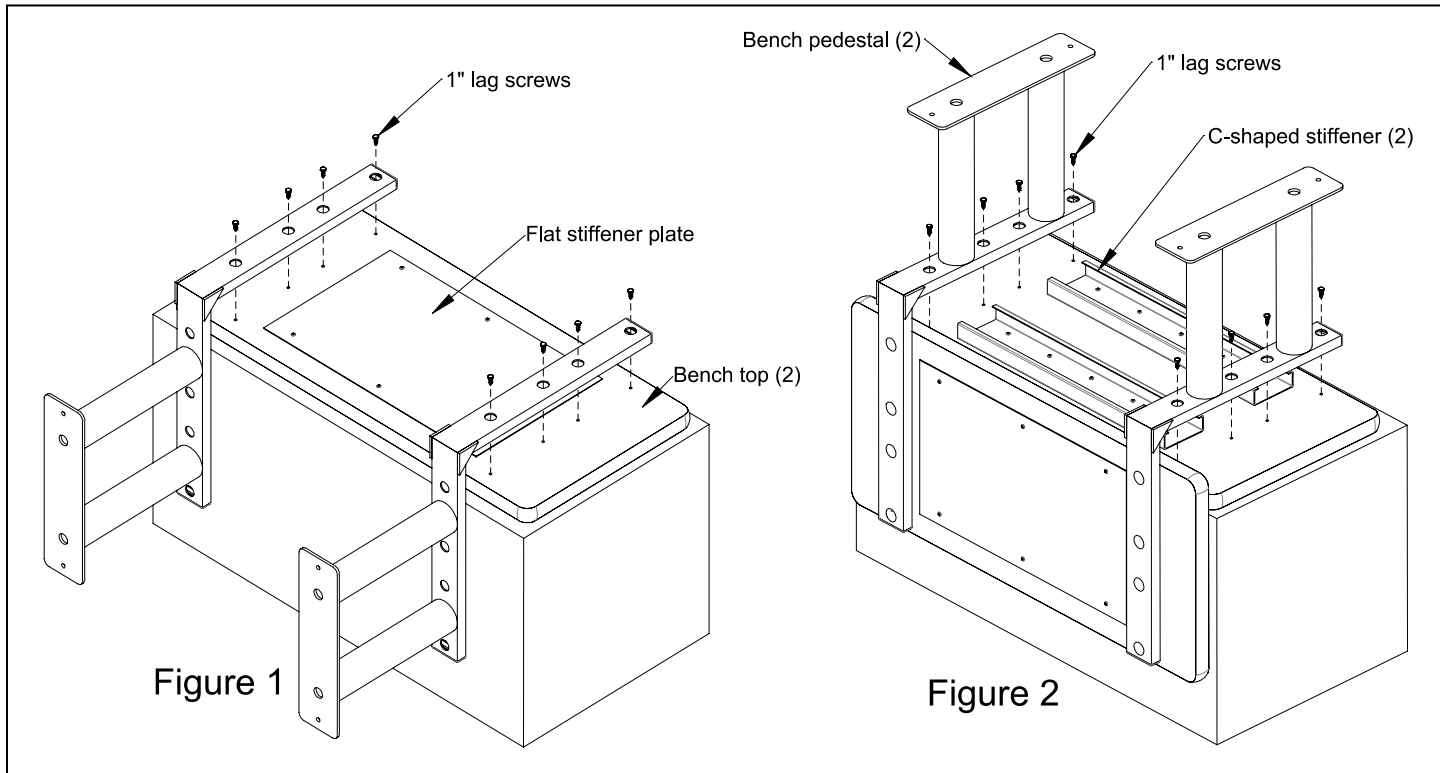

Preliminary Notes

There are two basic steps to assembly and installation:

1. The bench pedestals must be assembled to the bench top.
2. The bench assembly must be bolted to the floor.

Failure to bolt the bench assembly to the floor could result in injury to persons sitting on the bench.

Since various types of floors require different types of fasteners, floor installation hardware is not provided.

Two bench pedestals are provided with two bench tops, along with three stiffeners pre-installed on the bench tops. All necessary holes are pre-drilled in the wood bench top. Sixteen (16) 1/4" diameter x 1" long lag screws are provided for attaching the bench pedestals to the bench top.

CAUTION: using power tools to fasten screws into the bench top may cause screws to strip and damage the wood. Install screws by hand only and do not overtighten.

Assembly

Locate the bench top with the pre-installed flat stiffener plate and place it upside down on a flat raised work surface, so that the stiffener is facing up. Align the vertical members of the two bench pedestals with the two outer rows of large holes, as shown in Figure 1. Fasten pedestals to the bench top using eight (8) lag screws, and install round hole plugs in all holes on the pedestals' vertical members.

Place the remaining bench top upside down on the work surface. Align the horizontal members of the pedestals as before, and as shown in Figure 2. Fasten pedestals to the bench top using the remaining lag screws, and install round hole plugs on the horizontal members.

Complete the installation by fastening the assembled bench to the floor.

SALSBURY INDUSTRIES

18300 Central Avenue, Carson, CA 90746-4008
Phone: 1-800-562-5377 Int'l Phone: 323-846-6700
Fax: 1-800-562-5399 Int'l Fax: 323-846-6800
www.lockers.com engineering@lockers.com