

Standard Lockers – 61000 Series

Single Tier Installation Instructions

Thank you for selecting Salsbury's standard single tier lockers. We are confident that the quality and construction of the lockers will prove to be a good investment. These instructions are intended to assist you in assembling the lockers. The lockers should then be placed in the installed location and anchored to the floor, wall, or to both. Individual job conditions will dictate the type of anchor fasteners.

Preliminary Note

Please read the complete assembly instructions before attempting to assemble the lockers. Check the materials to be sure that they are correct for the job and that there is no damage.

Be careful to use the correct hardware. Use screw no. 1 all around with screw heads out, except where noted. Lockers should be assembled in groups as indicated in the order of the drawings.

The essential tools required for assembling the lockers are a 5/16" nut driver and 2 small nail punches or drift pins for hole alignment. The lockers should be assembled on a flat level surface and installed in position, anchoring to the floor or wall, as required.

See the illustration to the right to identify the locker parts. Note that the sloping hood, front base, end base, and name plate are optional items and their assembly is covered by a separate installation instruction. Also note that the coat rod is included with the 18" deep models only.

Assembly

1. Fasten a top, bottom, and side to a back. The top and bottom are identical parts and should have the flanges down. Insert a rear leg and fasten. See Illustration 1.

2. Fasten a shelf in position under the top. See Illustration 2.

For a one-wide locker, skip to Step 4.

Parts Identification

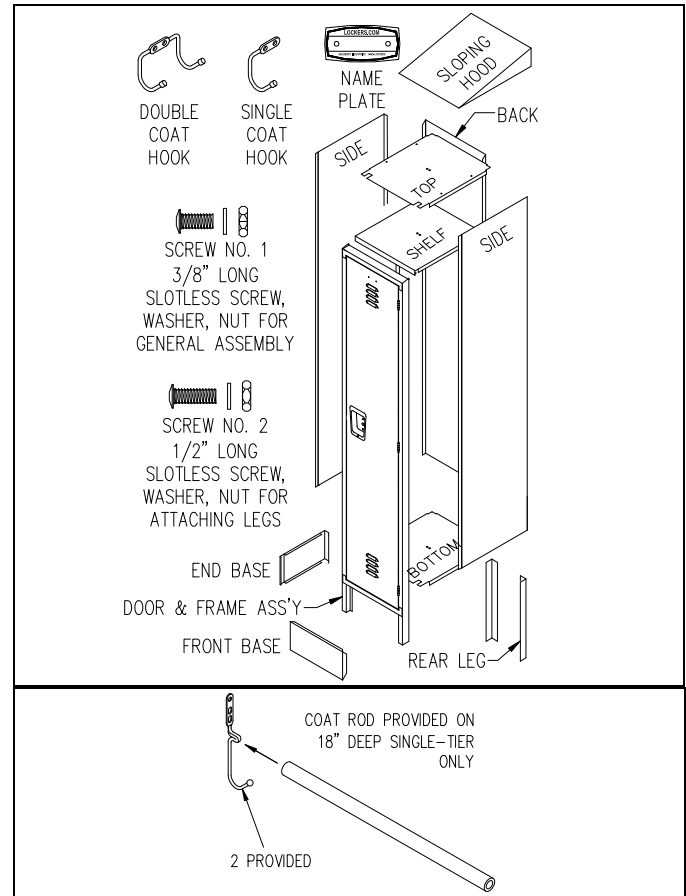

Illustration 1

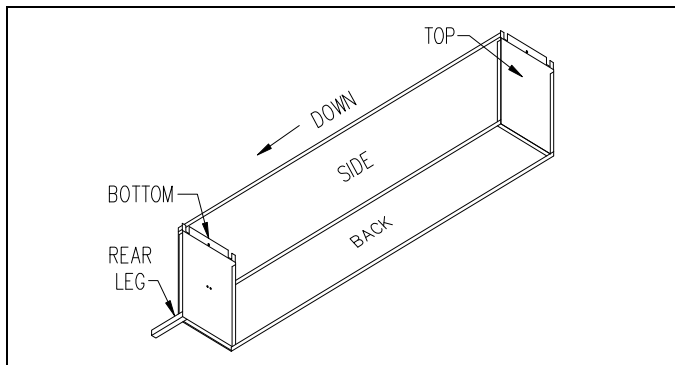
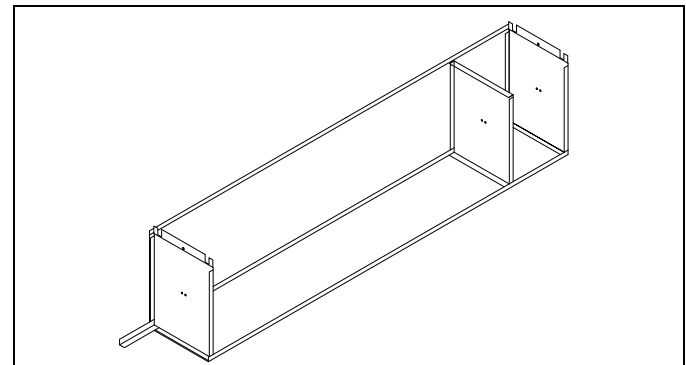

Illustration 2



SALSBUURY INDUSTRIES

1010 East 62nd Street, Los Angeles, CA 90001-1598
 Phone: 1-800-562-5377 Int'l Phone: 323-846-6700
 Fax: 1-800-562-5399 Int'l Fax: 323-846-6800
 www.lockers.com engineering@lockers.com

Standard Lockers – 61000 Series

Single Tier Installation Instructions

Assembly (continued)

3. Position additional sides, backs, tops, bottoms, and shelves and fasten in place. See Illustration 3.

4. Add a last side (flange in) and the other leg. See Illustration 4.

5. Attach the door and frame assemblies, ensuring that the front edges of the sides are inside a frame assembly flange and not between frames. See Illustration 5.

6. Fasten the last door and frame assembly into place, ensuring that they are all fastened correctly. See Illustration 6.

7. Finally, install coat hooks below the top and lock hole fillers into the doors. If there are built-in locks, install locks instead of lock hole fillers.

Illustration 3

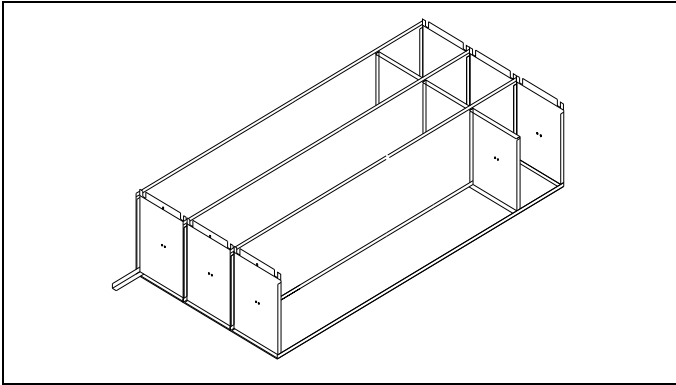

Illustration 5

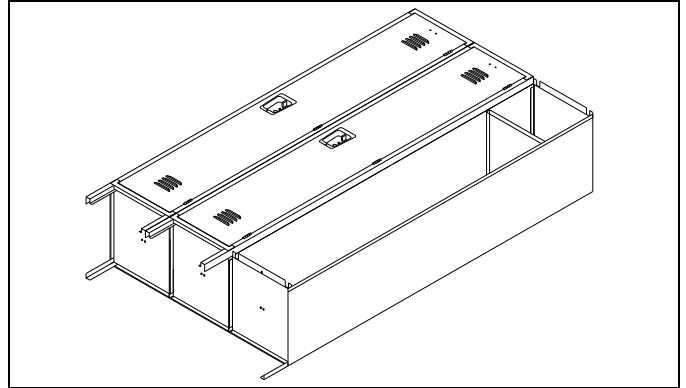

Illustration 4

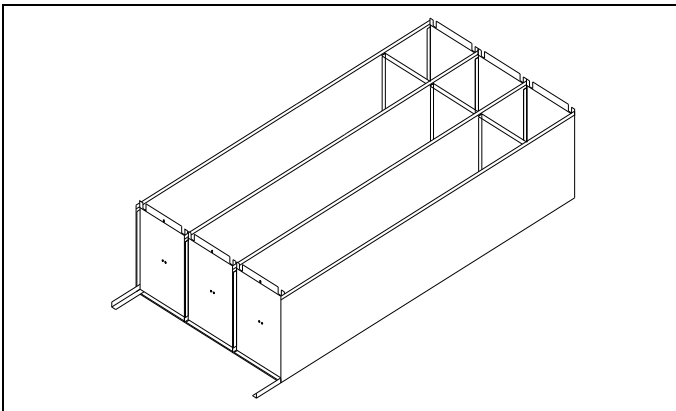
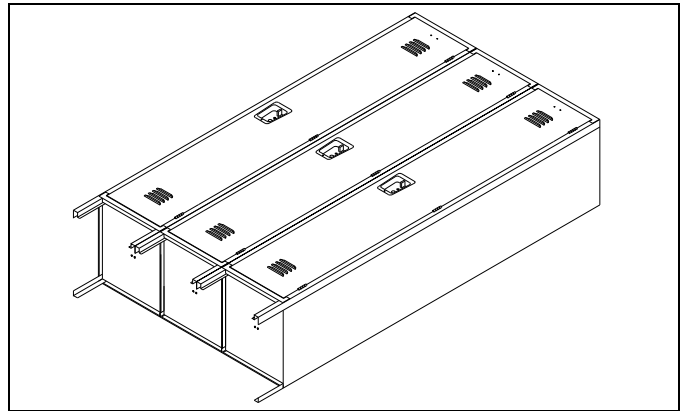
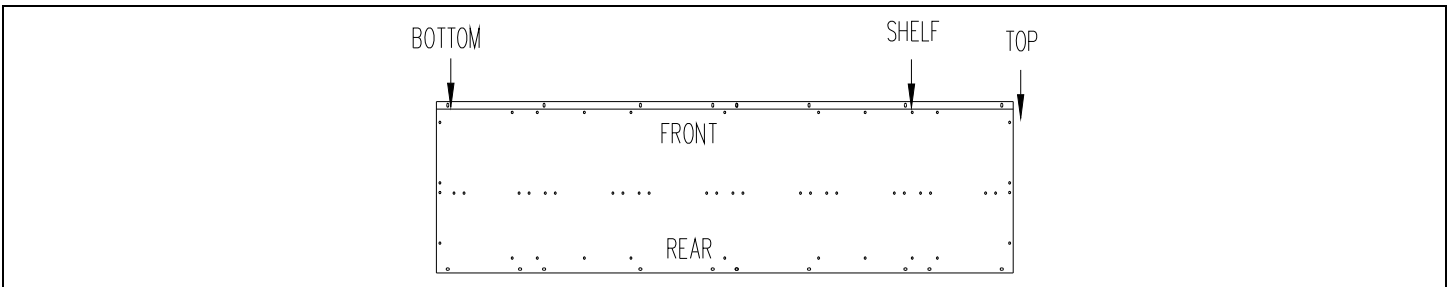

Illustration 6



Side Panel Hole Locations for Shelves



SALSBURY INDUSTRIES

1010 East 62nd Street, Los Angeles, CA 90001-1598
 Phone: 1-800-562-5377 Int'l Phone: 323-846-6700
 Fax: 1-800-562-5399 Int'l Fax: 323-846-6800
www.lockers.com engineering@lockers.com

Standard Lockers – 61000 Series

Installation Instructions - Options

Thank you for selecting Salsbury's standard single tier lockers. We are confident that the quality and construction of the lockers will prove to be a good investment. These instructions are intended to assist you in assembling option items into the locker. The name plates, front bases, end bases, and sloping hoods are each separate option items and may or may not be included in your order.

Name Plates

The name plates are installed with #4 slotless screws and nuts.

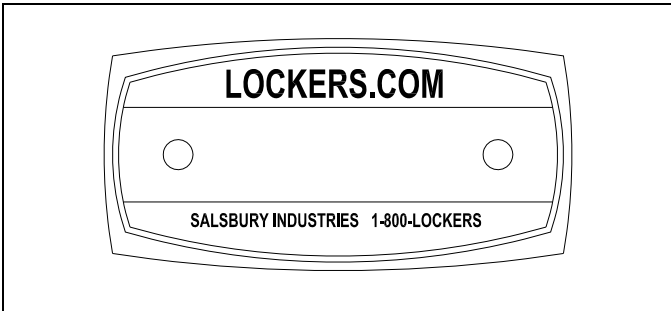

Sloping Hoods

The sloping hoods are assembled and installed on the locker units with #10 x 3/8" slotless screws and nuts. The side plates should be installed inside the flanges of the sloping hood. Only 1 side panel should be assembled between adjacent sloping hoods.

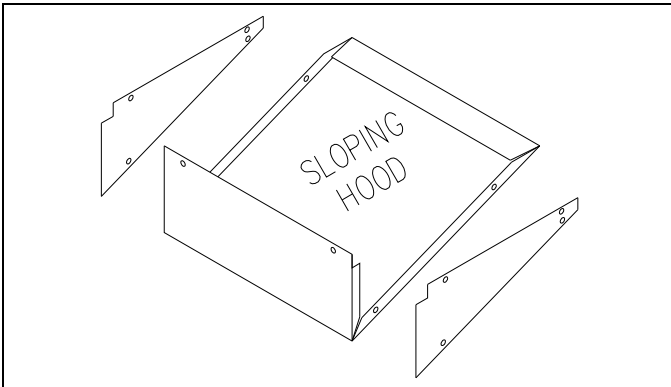

Front Bases and End Bases

The front bases are simply snapped into position between the two legs in the front of the locker unit. No fasteners are required due to the dimples on the front base flanges.

The end bases are installed and fastened with 2 screws and nuts such that the end base front edge is inserted inside the locker front leg with the end base rear flanges wrapped around the outside of the locker rear leg.

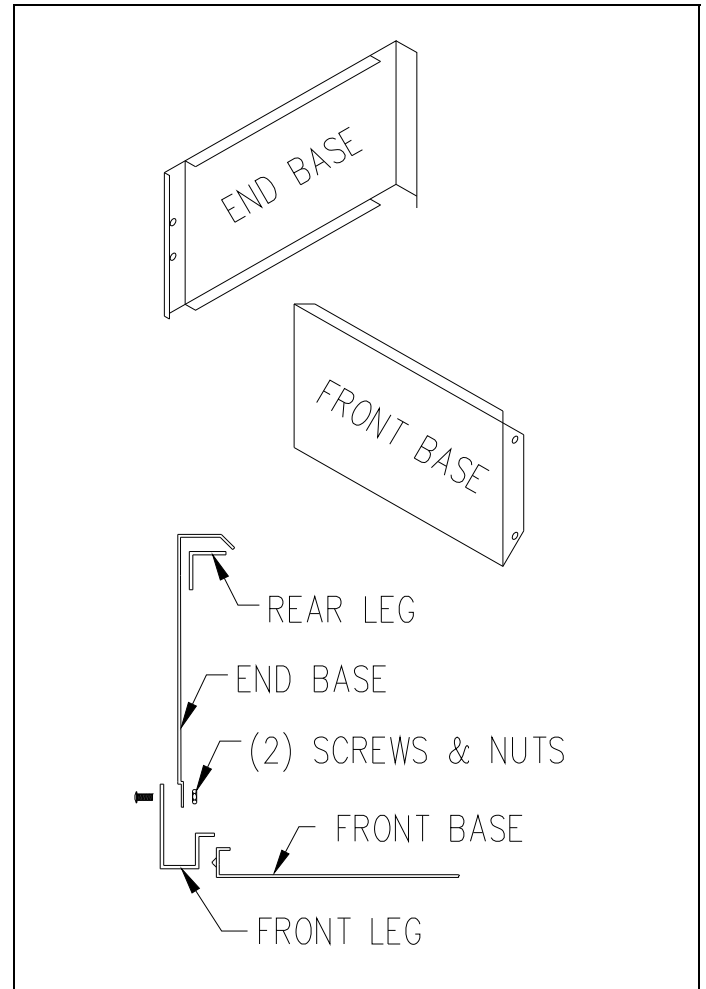

SALSBURY INDUSTRIES

1010 East 62nd Street, Los Angeles, CA 90001-1598
Phone: 1-800-562-5377 Int'l Phone: 323-846-6700
Fax: 1-800-562-5399 Int'l Fax: 323-846-6800
www.lockers.com engineering@lockers.com

Standard Lockers – Locker Benches

Assembly & Installation Instructions

Thank you for selecting Salsbury's 77770 series locker aluminum benches. We are confident that the quality and construction of this product will provide years of maintenance free use.

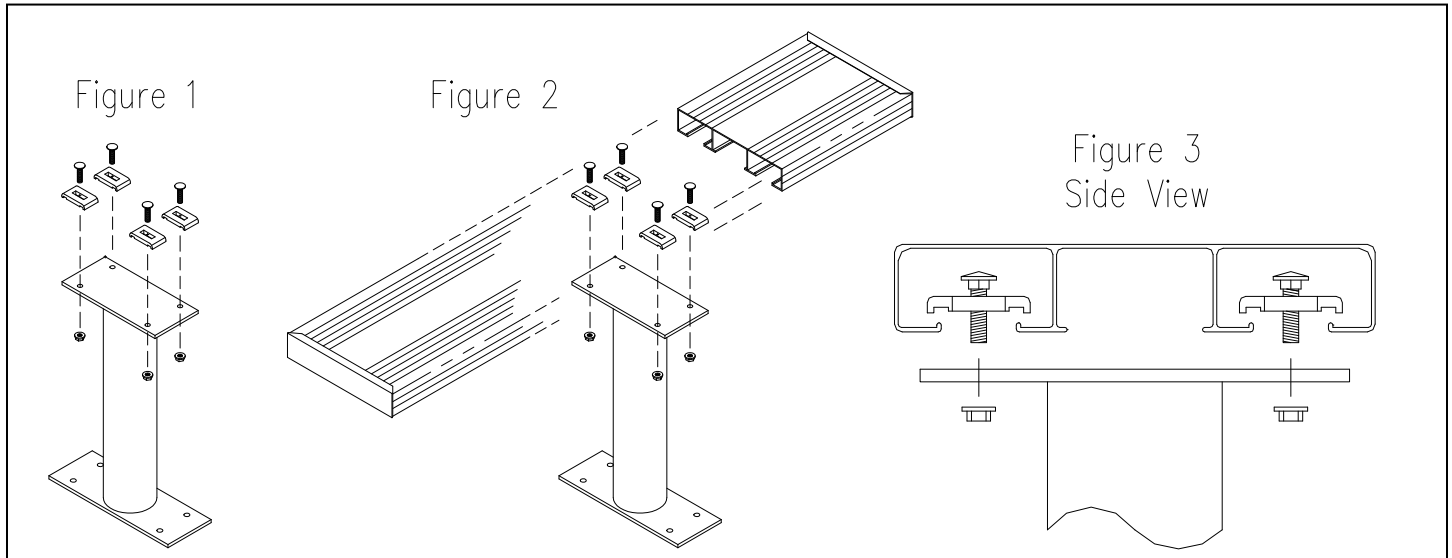

Preliminary Notes

There are two basic steps to assembly and installation:

1. The bench pedestals must be assembled to the bench top.
2. The bench assembly must be bolted to the floor.

Failure to bolt the bench assembly to the floor could result in injury to persons sitting on the bench.

Since various types of floors require different types of fasteners, floor installation hardware is not provided. The hardware provided is for fastening the bench pedestals to the bench top.

Two bench pedestals are provided for each bench top. Each bench pedestal should be installed 6" from the end of each side of the bench top.

Assembly

Install one of the 5/16" by 1-1/4" long carriage bolts through a straddle clamp and loosely attach it to the bench pedestal with one of the 5/16" serrated flange nuts as shown in Figure 1. The straddle clamps should be installed on the end of the bench pedestal with the smaller plate. Do this with the remaining three straddle clamps in the first bench pedestal and repeat for the four clamps in the second bench pedestal.

Set the bench top on a flat surface upside down. Rotate each of the straddle clamps on a bench pedestal aligned such that they can be inserted into the bottom of the bench top as shown in Figure 2. Rotate them each 90 degrees so that they straddle and grip the inside lips of the bench top when the nuts are tightened as shown in Figure 3. Ensure that the straddle clamps are aligned with the lips. Also ensure that the square section of the carriage bolts are inside the square slots in the straddle clamps. Tighten the nuts until the clamps are not quite gripping the lips inside the bench top. Slide the bench pedestal to a position 6" from one end of the bench top. Adjust the position of the bench pedestal so that it is centered crosswise under the bench top and tighten the nuts securely.

Repeat for the other bench pedestal, installing it 6" from the other end of the bench top.

Complete the installation by fastening the assembled bench to the floor.

SALSBURY INDUSTRIES

1010 East 62nd Street, Los Angeles, CA 90001-1598
Phone: 1-800-562-5377 Int'l Phone: 323-846-6700
Fax: 1-800-562-5399 Int'l Fax: 323-846-6800
www.lockers.com engineering@lockers.com