

72000 Series Team Benches - with Shelf

Assembly & Installation Instructions

Thank you for selecting Salsbury combination aluminum team benches with shelf. We are confident that the quality and construction of this product will provide years of maintenance free use.

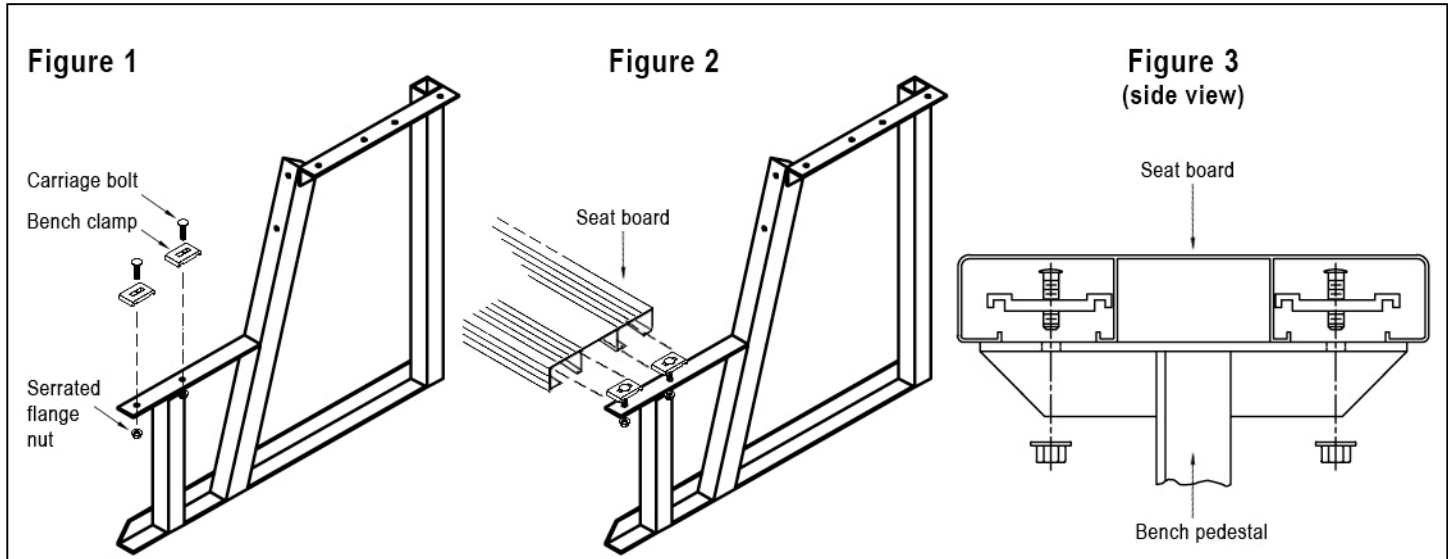

Preliminary Notes

There are three basic steps to assembly and installation:

1. The bench pedestals must be assembled to the seat board.
2. The back rest and shelf must be assembled to the bench pedestals.
3. The bench assembly must be bolted to the floor.

Failure to bolt the bench assembly to the floor could result in injury to persons sitting on the bench.

Since various types of floors require different types of fasteners, floor installation hardware is not provided. The hardware provided is for fastening the bench assembly together.

A seat board, back rest and two (2) shelf planks are provided for all models. 7-1/2' models come with two (2) pedestals, 15' benches come with three (3) pedestals, and 21' benches come with four (4) pedestals.

Assembly

Install one of the 5/16" by 1-1/4" long carriage bolts through a bench clamp and loosely attach it to the bench pedestal with one of the 5/16" serrated flange nuts as shown in Figure 1. Do this with the remaining bench clamps in the first bench pedestal and repeat for the remaining pedestal(s).

Align each of the bench clamps on the bench pedestals such that they can be inserted into the bottom of the seat board as shown in Figure 2.

Begin sliding the seat board between the clamps and pedestal. For 7-1/2' wide benches, position seat board 9" from one end and align with pedestal. For 15' and 21' wide benches, slide the seat board into position

1-6" from one end. Ensure that the bench clamps grip the inside lips of the seat board, while also ensuring that the square section of the carriage bolts are inside the square slots in the bench clamps, when the nuts are tightened as shown in Figure 3. Tighten the nuts until the clamps are not quite gripping the lips inside the seat board. Adjust the position of the bench pedestal so that it is centered crosswise under the seat board and continue tightening nuts securely.

Repeat for the other bench pedestal(s), installing them according to the measurements in Figure 4. For 7-1/2' benches, install last pedestal 9" from the other end of seat board. For 15' and 21' benches, install last pedestal 1' 6" from the other end of seat board.

For the back rest, install bench clamps and carriage bolts to pedestal using the same process as used for the seat board. See Figure 5. Position and slide one end of the back rest onto the first pedestal and continue sliding through the remaining pedestals. Align back rest with seat board position and tighten nuts securely.

Insert the tube caps as shown in Figure 5.

For the shelf planks, repeat the same process as used for back rest.

Install end caps on both ends of the seat board, back rest and shelf planks by inserting #8 1/2" screws on the under side of the seat board and shelf planks and the rear side of the back rest. See Figure 6.

Complete the installation by fastening the assembled bench to the floor.

SALSBUURY INDUSTRIES

1010 East 62nd Street, Los Angeles, CA 90001-1598
 Phone: 1-800-562-5377 Int'l Phone: 323-846-6700
 Fax: 1-800-562-5399 Int'l Fax: 323-846-6800
 www.lockers.com engineering@lockers.com

72000 Series Team Benches - with Shelf

Assembly & Installation Instructions

Figure 4

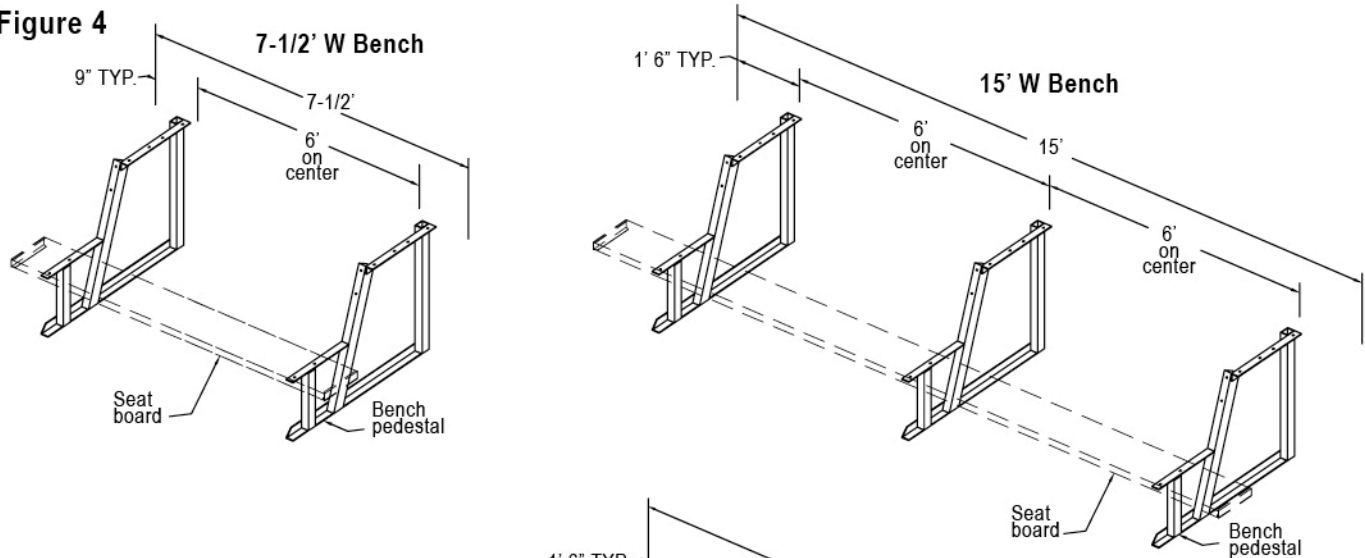

Figure 5

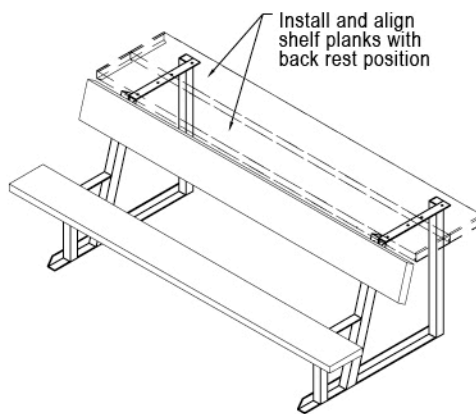
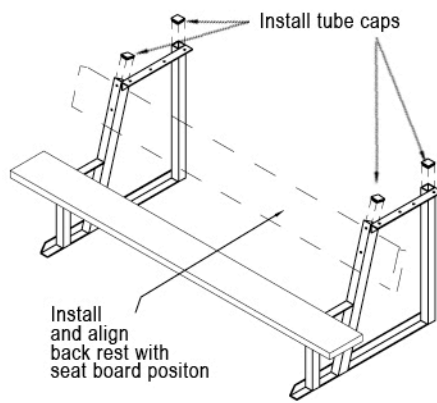
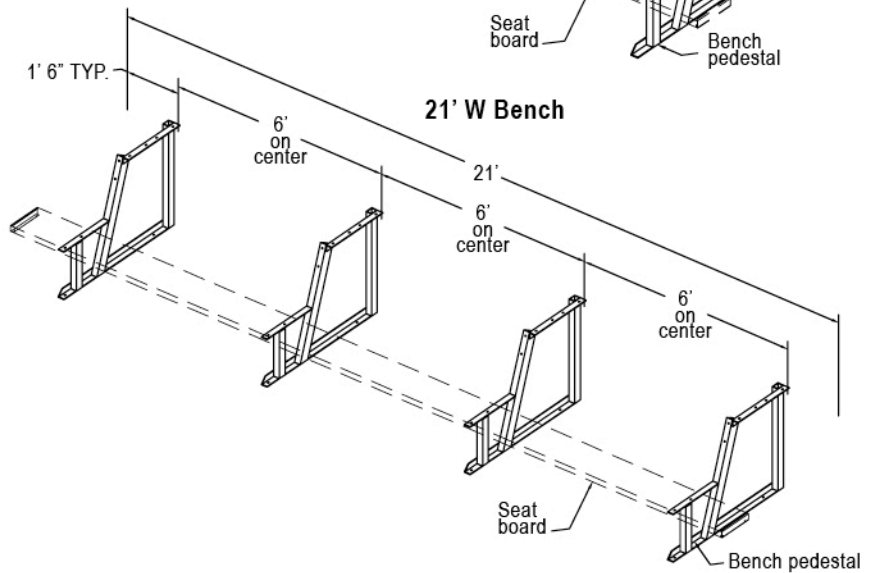
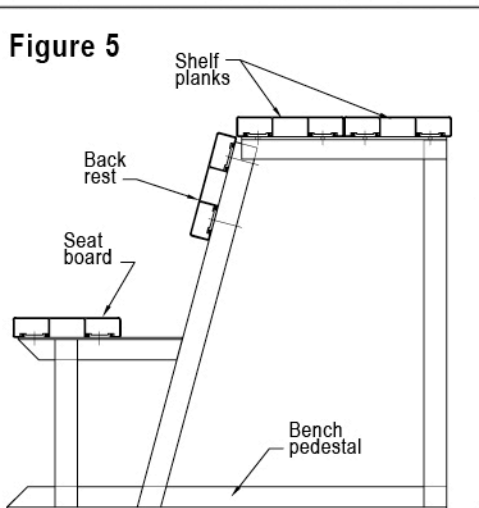
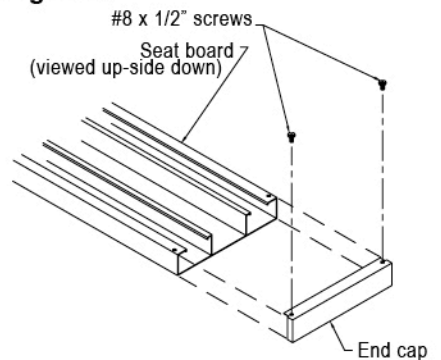

Figure 6



SALSBUURY INDUSTRIES

1010 East 62nd Street, Los Angeles, CA 90001-1598
 Phone: 1-800-562-5377 Int'l Phone: 323-846-6700
 Fax: 1-800-562-5399 Int'l Fax: 323-846-6800
www.lockers.com engineering@lockers.com