

(NOTE: SOLID OAK EXECUTIVE LOCKER SHOWN WITHOUT SIDE PANEL OR CROWN MOLDING. PLEASE ORDER SEPARATELY.)

MODEL #12164
DOUBLE TIER SOLID OAK
EXECUTIVE LOCKER - 1 WIDE

(2) LOCKER COMPARTMENTS
EACH COMPARTMENT:
14 $\frac{3}{4}$ " W x 34 $\frac{3}{4}$ " H x 22 $\frac{3}{4}$ " D

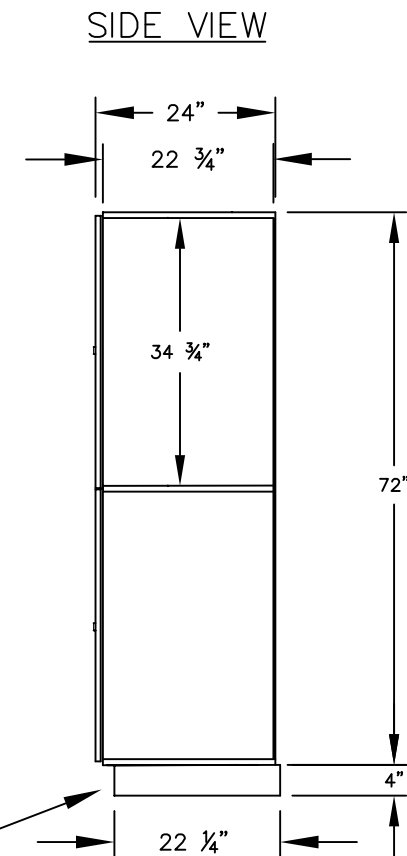

(BASES ARE MADE OF INDUSTRIAL GRADE PARTICLEBOARD AND ARE COVERED IN A DURABLE BLACK LAMINATE. PLEASE SET BASE TO ALLOW $\frac{5}{8}$ " BETWEEN THE BACK OF THE LOCKER AND THE WALL FOR AIR VENTILATION.)

MODEL #12164

24" DEEP DOUBLE TIER
SOLID OAK EXECUTIVE LOCKER
SIX FEET HIGH (ADD 4" FOR BASE)

AVAILABLE FINISHES:
LIGHT OAK, MEDIUM OAK, DARK OAK

DRAWN: 10/14

***Established in 1936, Salsbury Industries
is the industry leader in manufacturing and distributing
quality lockers and storage solutions.***

1010 E. 62ND STREET
LOS ANGELES, CA 90001
PHONE: (800) 562-5377
FAX: (800) 562-5399
email: engineering@lockers.com