

(NOTE: PREMIER LOCKER SHOWN WITHOUT SIDE PANEL OR SLOPING HOOD. PLEASE ORDER SEPERATELY.)

**MODEL #15-47164**  
**15" WIDE DOUBLE TIER 'S' STYLE PREMIER WOOD LOCKER – 1 WIDE WITH STANDARD HASPS**

(2) LOCKER COMPARTMENTS  
 EACH COMPARTMENT:  
 13-3/4" W x 40-3/4" H x 22-3/4" D

(THE DOUBLE TIER 'S' STYLE PREMIER LOCKER INCREASES EACH COMPARTMENT ON ONE SIDE TO ACCOMMODATE GARMENTS.)

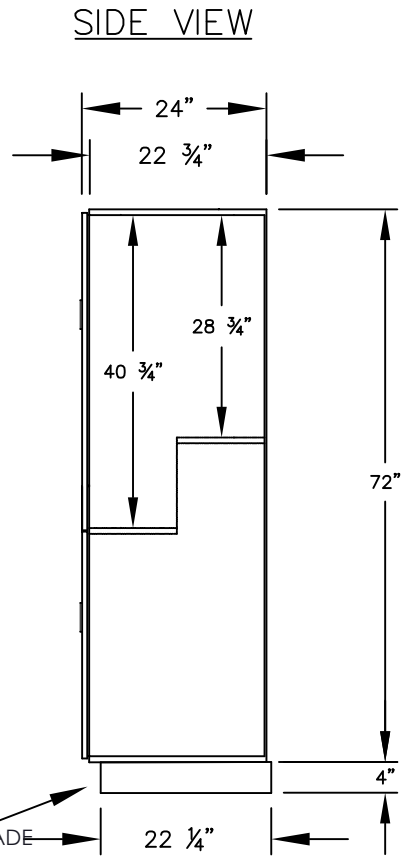

(BASES ARE MADE OF INDUSTRIAL GRADE WOOD AND ARE COVERED IN A DURABLE BLACK LAMINATE. PLEASE SET BASE TO ALLOW 5/8" BETWEEN THE BACK OF THE LOCKER AND THE WALL FOR AIR VENTILATION.)

**MODEL #15-47164**

**15" WIDE DOUBLE TIER 'S' STYLE PREMIER WOOD LOCKER WITH STANDARD HASPS**  
**SIX FEET HIGH (ADD 4" FOR BASE)**

AVAILABLE LOCKER FINISHES: ARCTIC WHITE, WINTER FOG, CARBON MESH, SILVER TEAK, RED OAK, SKYLINE WALNUT

AVAILABLE HASP FINISHES: BLACK OR SILVER

DRAWN: 12/2025

***Established in 1936, Salsbury Industries is the industry leader in manufacturing and distributing quality lockers.***

18300 CENTRAL AVENUE  
 CARSON, CA 90746-4008  
 PHONE: (800) 562-5377  
 FAX: (800) 562-5399  
 email: [engineering@lockers.com](mailto:engineering@lockers.com)